

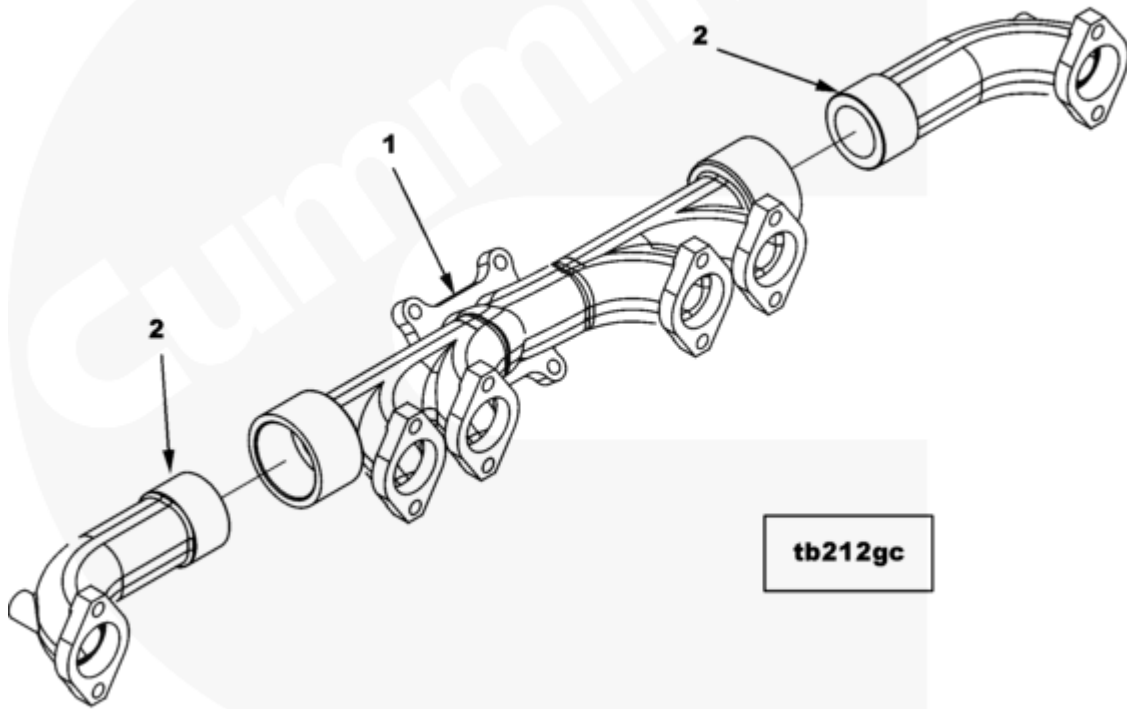

# Parts Catalog - Option Detail

Electronic Parts Catalog - Option Detail				
Option	Group	Graphic	Film Card	Date
TB2323	10.06.1	tb212gc	II	06-FEB-06
<b>Engines</b>	ISM CM570, ISM CM570/870, ISM CM875, ISM CM876, ISM CM876 E, ISM11 CM876 M103, ISM11 CM876 SN, M11 CELECT, M11 CELECT PLUS, M11 MECHANICAL, QSM11 CM570, QSM11 CM876			

©Cummins Inc



[SMALL](#) | [MEDIUM](#) | [LARGE](#)

Cart	Ref No	Part Number	Part Description	Required	Remarks
<input type="button" value="View My Cart"/>					
		TB2323	Turbocharger Arrangement		
					Turbocharger Arrangement
					Engine Aspiration: Charged
					Air Cooled

					Turbocharger Location: Low
					Mount
					Exhaust Outlet Location:
					Rear Out
					Turbo Outlet Conn Flange OD:
					146.05mm (5.75 in.)
					Turbocharger Type: Wastegate
					Wastegate Rod-to-Crank Angle
					(Deg): 90
					Turbo C/L Vertically from
					Crank C/L: 353.00mm (13.9 in)
					Turbo C/L Horizontally from
					Crank C/L: 361.00mm
					(14.21 in.)
					Exhaust Manifold Mtg
					Included: No
					Turbo Oil Supply Line Type:
					O Ring Face Seal
					Turbo Mtg Flange Bolt Circle
					Diameter: 129.06mm (5.08 in.)
					Intake Manifold Included: in
					IMI Option
					Closed Crankcase Ventilation
					Compatible: No
					Turbocharger Model: HX55
					FFOB to Turbo Compressor
					Inlet Flange: 293, 294, or
					269mm
					Turbo Comp Outlet Angle from
					Horz: 45

<input type="checkbox"/>	1	<a href="#">3104237</a>	Exhaust Manifold	1	
<input type="checkbox"/>	2	<a href="#">4003994</a>	Exhaust Manifold	2	

© 2019 Cummins Inc., Box 3005, Columbus, IN 47202-3005 U.S.A.  
Terms of Use and Disclaimers | Recommended System Requirements  
Need Assistance? Please click on the Contact Us button in the top right corner of any page.